

The LED-95 Series combines a stylish new look, low-profile, contemporary appearance with LED economy and dependability. Fully adjustable heads provide path of egress for any commercial application.

Model: \_\_\_\_\_ Date: \_\_\_\_\_  
 Accessories: \_\_\_\_\_  
 Job Name: \_\_\_\_\_ Type: \_\_\_\_\_

### FEATURES & BENEFITS

- 1.5 Watt LED lamp heads deliver up to 25' spacing
- Optional remote capability (R) of 3.4 Watts for 90 minutes
- Optional Guardian Self-test/Self-diagnostics (G2)
- Suitable for Damp Locations
- California Energy Commission (CEC) Compliant



### SPECIFICATIONS

Illumination:	Fully adjustable 1.5W LED lamps
Housing:	UL 94 V-0 flame retardant thermoplastic
Input:	120/277VAC Dual Primary, 60Hz
Battery:	Maintenance-free NiCad battery
Operating Temp:	0°C to 40°C (32°F to 104°F)
Run Time:	UL Listed 90 minute emergency run time, 24 hour recharge time
Mounting:	Wall or ceiling with universal mounting pattern and keyhole slots
Finishes:	Black or White
Certifications:	UL 924 Listed for Damp Location, meets or exceeds NEC requirements and NFPA 101
Warranty:	Any component that fails due to a manufacturing defect is guaranteed for five years with a separate five year prorated warranty on the battery. The warranty does not cover physical damage, abuse or instances of uncontrollable natural forces. See the full Exitronix warranty document for detailed information. (Terms and Conditions apply)

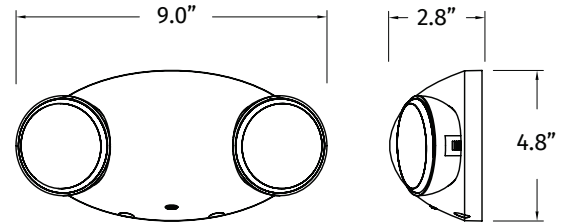

## CONSTRUCTION

The LED-95 is a precision molded enclosure including lamp housings constructed of UV stable, UL 94 V-0 flame-retardant high-temperature thermoplastic. Units resist denting, peeling, scratching and corrosion. Not recommended for outdoor use. Tool-less access provided for easy maintenance. Universal J-box mounting pattern and keyhole slots provided for simple installation.

## ILLUMINATION

Illumination is provided by high-intensity, long-life LEDs consuming only 1.5 Watts of power per head. LEDs provide excellent illumination while maximizing energy efficiency.

## ELECTRICAL

### Input

Dual-voltage input 120/277VAC @ 60Hz.

Less than 1 Watt power consumption.

### Nickel Cadmium Battery – NiCad

Exitronix NiCad batteries are maintenance-free and offer high discharge rates and continue to perform in a vast temperature range from 0 to 40°C (32°F to 104°F). NiCad technology provides long-lasting, safe and reliable performance.

### Brownout Circuit

The brownout circuit monitors the flow of AC current to the unit and triggers the emergency lighting system once a set reduction of AC power occurs. This dip in the voltage will cause many fixtures to extinguish causing loss of normal lighting even though a total power failure has not occurred.

### Overload and Short Circuit Protection

The solid-state overload monitoring system in the DC circuit disconnects the lamp load from the battery should excessive wattage demands be made and automatically resets when the overload or short circuit is removed. This overload current protective characteristic eliminates the need for fuses or circuit breakers for the DC load.

### Solid-State Transfer

The unit features a solid-state switching transistor which eliminates damaged contacts or mechanical failures associated with relays. The switching circuit is designed to detect a loss of AC power and automatically energizes the lamps. Upon restoration of the AC voltage, the emergency lamps will switch off and the charger will automatically recharge the battery.

### Emergency Mode

The LED-95 will operate for a minimum of 90 minutes during a loss of power with a 24 hour maximum recharge time for the battery. The LED-95-\*R will run for 180 minutes in emergency mode if no remote load is connected.

### Test Button

The easily located test button allows for manual verification of proper operation of the transfer circuit and emergency lamps.

## SAMPLE PHOTOMETRICS

Using multiple units mounted at a typical 7.5' delivers 25' center-to-center spacing on a 3' wide egress path.

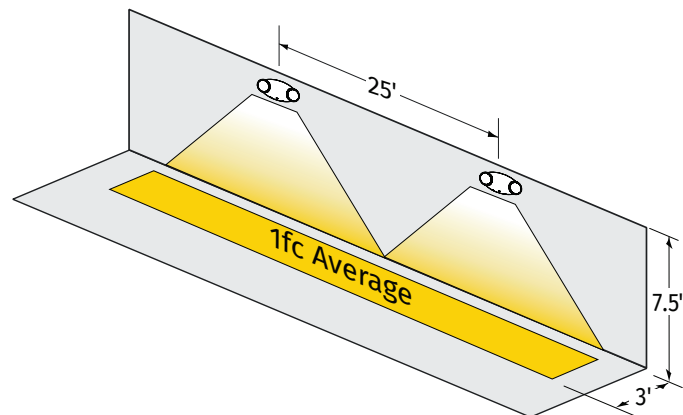

## INSTALLATION

Units are mountable in any orientation, on wall or ceiling surfaces. A universal mounting pattern and rear keyhole slots are provided.

### Damp Location Rated

Damp Location Rating ensures the fixture is designed to operate safely in outdoor locations that are protected from the direct elements. Damp Location Rated fixtures are also suitable for indoor installations. Products with Damp Location Ratings are not designed to withstand constant or significant moisture or direct contact with water or steam.

## OPTIONS

### Guardian Self-test/Self-diagnostics (Option: G2)

The Guardian circuit continuously monitors the operating condition of the AC power, battery supply voltage, emergency lamp continuity and charging circuit.

The purpose of this option is to provide visual signaling in response to a lamp, battery and/or battery charger. If a failure is detected, visual status will occur immediately via the CHARGER LED and/or the BATTERY FAULT LED. The LEDs will stay illuminated until the fault is corrected.

The Guardian circuit also monitors the transfer circuit as well as performing automatic code compliant testing in line with NFPA101 specifications.

### Remote Capable (Option: R)

The remote option provides this unit with an additional 3.4 Watts of external power for use with a single [RL52](#) or up to (2x) [MLED](#) remote lamps.

## CONFORMANCE TO CODES & STANDARDS

The LED-95 Series is Damp Location Rated, UL 924 Listed and CEC compliant. The series meets and exceeds the NEC requirements as well as NFPA 101.

Using multiple units mounted at a typical 7.5' delivers 25' center-to-center spacing on a 6' wide egress path.

